

产品规格书

Product Specification

锂离子电池 Li-ion Battery	
Name 名称:	磷酸铁锂电池
Model 型号:	IFP2770180AD 30Ah
Type 类型:	Energy storage Battery 储能型

Approval 批准	Checked 审核	Draft 制定



History of Revision

规格书修订记录

Date 日期	Contents 内容	Remarks 备注
2025-02-21	First Issue	

Contents 目录

1. Scope 试用范围.....	4
2. Parameters for Battery 主要技术参数.....	4
3. Battery Performance and Test 电池性能检查及测试.....	5
3.1 Appearance and Structure 外观和结构.....	5
3.2 Measurement Apparatus and Requirements 测试设备要求.....	5
3.3 Standard test condition 标准的测试条件.....	5
3.4 Standard charge 标准充电.....	5
3.5 Common Performance 产品的常规性能.....	6
3.6 Safety and Reliability Performance 产品安全性和可靠性.....	7
3.7 Rest Period 搁置时间.....	8
4. Storage and Others 贮存及其它事项.....	8
4.1 Long Time Storage 长期贮存.....	8
4.2 Others 其它事项.....	8
5. Battery Size Draft 电池外形尺寸图.....	8
Appendix.....	9
1. Charging 充电.....	9
1.1 Charging Current 充电电流.....	9
1.2 Charging Voltage 充电电压.....	9
1.3 Charging Temperature 充电温度.....	10
1.4 Prohibition of reverse charging 禁止反向充电.....	10
2. Discharging 放电.....	10
2.1 Discharging Current 放电电流.....	10
2.2 Discharging Temperature 放电温度.....	10
2.3 Over-discharging 过放电.....	10
3. Store 贮存.....	11
4. Handling Instructions 电池的注意事项.....	11



1. Scope 适用范围

This specification is made for lithium ion battery which type is IFP2770180AD 30Ah. And the product is manufactured by Shenyang King Power Tech. Co. Ltd.

本规格书适用沈阳国科金能科技有限公司生产的 IFP2770180AD 30Ah 锂离子可充电电池。

2. Parameters for Battery 主要技术参数

No.	Items	Criteria	Remarks
2.1	Shell 壳体	3003 铝合金	Aluminum Alloy 3003
2.2	Nominal Capacity 标称容量	30Ah	25±2°C, 0.5C discharge capacity
2.3	Energy 能量	96Wh	
2.4	Nominal Voltage 标称电压	3.2V	
2.0	Open Circuit Voltage 出厂电压	3.2-3.4V	
2.6	Internal Impedance 内阻	≤3.5.mΩ	AC 1kHz after standard charge 标准充电后 AC 1kHz 测试
2.7	End of Charge Voltage 充电截止电压	3.65V±0.05V	0.05C (1.5A) 截止
2.8	Std. Charge Current 标准充电电流	15A	0.5C
2.9	Std. Discharge Current 标准放电电流	15A	0.5C
2.10	Max. Continuous Charge Current 最大持续充电电流	30A	1C
2.11	Max. Continuous Discharge Current 最大持续放电电流	90A	3C
2.12	Discharge cut-off Voltage 放电截止电压	2.0V	
2.13	Operating Temperature 工作温度	0~+60°C	Charging 充电
2.14		-20~+60°C	Discharging 放电
2.15	Optimal storage temperature 最佳贮存温度	25°C ±2°C	
2.16	Weight 重量	≤665g	

3. Battery Performance and Test 电池性能检查及测试

3.1 Appearance and Structure 外观和结构

The shell should be no clear defect as scratch, burr and other mechanical scratch, and the connector should be no rust dirt. The structure and dimensions see attached drawing of the battery.

电池的表面应无明显的划痕毛刺及其它机械划伤，外漏的金属端子应无锈蚀污垢。结构尺寸见电池的外形尺寸图。

3.2 Measurement Apparatus and Requirements 测试设备要求

(1) Dimension measuring Instrument 尺寸测量设备

The dimension-measurement should be implemented by instruments with equal or more precision scale of 0.01mm.

测量尺寸的仪器之精度应不小于 0.01mm。

(2) Voltmeter 电压表

Standard class specified in the national standard or more sensitive class having inner impedance not less than 10k Ω /V

国家标准或更严格等级，内阻不小于 10k Ω /V。

(3) Ammeter 电流表

Standard class specified in the national standard or more sensitive class. Total external resistance including ammeter and wire is less than 0.01 Ω .

国家标准或更严格等级，外部总内阻包括电流表和导线应小于 0.01 Ω 。

(4) Impedance Meter 内阻测试仪

Impedance should be measured by a sinusoidal alternating current method (AC 1kHz LCR meter).

内阻测试仪测试方法为交流阻抗法 (AC 1kHz LCR)。

3.3 standard test condition 标准的测试条件

Test should be conducted with new batteries within one month after shipment from our factory and the cells shall not be cycled more than five times before the test. Unless otherwise defined, test and measurement shall be done under temperature of 25 \pm 2 $^{\circ}$ C and relative humidity of 25~85%。

测试电池必须是本公司出厂时间不超过一个月的新电池，且电池未经过 5 次以上充放电循环。除非其它特殊要求，本产品规格书规定的测试的环境条件为：温度 25 \pm 2 $^{\circ}$ C，相对湿度 15%~90%。

3.4 standard charge 标准充电

Under 25 \pm 2 $^{\circ}$ C, full charge method, make sure the SOC of battery is 0%, set 0.5C(15A)current and with constant current charge to 3.65V then with constant voltage charge to current taper to 0.05C(1.5A) and stop charging, rest 1h.

在 25 \pm 2 $^{\circ}$ C 环境下充电，满充电方法：在电池 SOC 为 0%的前提下先 0.5C(15A)恒流充电至 3.65V，然后恒压充电至电流减小至 0.05C (1.5A) 截止，静置 1h。

3.5 Common Performance 产品的常规性能

No.	Items/项目	Testing method and estimate criteria 测试方法和判定标准
1	The Standard Charging Mode 标准充电模式	The standard charging mode: under the temperature of $25 \pm 2^{\circ}\text{C}$, discharge the battery to 2.0V with 0.5C current, rest 1h, then charge the battery under the current of 0.5C until the voltage reaches to 3.65V, then charge to constant voltage until the current tapers to 0.05C and stop charge, rest 1h. 标准充电方法: 在 $25 \pm 2^{\circ}\text{C}$ 条件下, 电池先用 0.5C 放电至 2.0V, 休眠 1h, 然后用 0.5C 充电, 当电池电压达到 3.65V 时改为恒压充电, 直到充电电流达到 0.05C 时停止充电, 静置 1 小时
2	Discharge Performance 放电性能	Charge the battery with standard charging mode, then discharge with 1C current until the voltage reaches to 2.0V, the discharge capacity should $\geq 30\text{Ah}$. 将电池按标准充电模式充好电后, 再以 1C 放电至 2.0V, 要求放电容量 $\geq 30\text{Ah}$ 。
3	Cycle Performance 循环性能	Under the temperature of $25 \pm 2^{\circ}\text{C}$, charge the battery under the current of 0.5C, when the voltage reaches to 3.65V changes to constant voltage charge until the current tapers to 0.05C, then stop charging and rests for 30min, then discharge with 0.5C to 2.0V. Cycle with the above mode, when 3 consecutive discharge capacity $< 70\%$ the nominal capacity, stop cycling. The cycle life is required ≥ 4000 times. 在 $25 \pm 2^{\circ}\text{C}$ 条件下, 按 0.5C 充电至 3.65V 时, 改恒压充电, 直到电流下降到 0.05C, 停止充电, 静置 30min, 0.5C 放电至 2.0V。按此模式进行循环, 当连续 3 次放电容量 $< 70\%$ 标称容量时终止实验。要求循环寿命 ≥ 4000 次。
4	Charged Storage Characteristics 荷电保持能力	Charge the battery with standard charging mode, the battery should be rest under the temperature of $25 \pm 2^{\circ}\text{C}$ for 28d then discharge under the current of 1C to 2.0V. The discharge capacity is required $\geq 95\%$ the original capacity. 将电池按标准充电模式充好电后, 在 $25 \pm 2^{\circ}\text{C}$ 条件下电池开路静置 28 天, 然后 1C 放电至 2.0V。要求放电容量 $\geq 95\%$ 初始容量。
5	High temperature Storage Characteristics 高温储存性能	Charge the battery with standard charge mode, put the battery into $55^{\circ}\text{C} \pm 2^{\circ}\text{C}$ hot box and keep 7d, take out the battery after 7d and discharge with 1C current to 2.0V when the temperature reaches to RT. The discharge capacity is required $\geq 90\%$ the original capacity. 将电池按标准充电模式充好电后, 在 $55^{\circ}\text{C} \pm 2^{\circ}\text{C}$ 的高温箱中放置 7 天, 7 天后取出电池待温度降到室温以 1C 电流放电到 2.0V, 要求放电容量 $\geq 90\%$ 初始容量。

3.6 Safety and Reliability Performance 产品安全性和可靠性

No.	Items/项目	Testing method and estimate criteria 测试方法和判定标准
-----	----------	--



1	High Temperature Discharge Characteristics 高温放电性能	Charge the battery with standard charging mode, put the battery into hot box with $55 \pm 2^\circ\text{C}$ for 5h, then discharge with 1C to 2.0V. The discharge capacity is required $\geq 95\%$ nominal capacity. 将电池按标准充电模式充好电后，放入 $55 \pm 2^\circ\text{C}$ 恒温箱静置 5h 后，然后以 1C 电流放电至 2.0V，要求放电容量 $\geq 95\%$ 标称容量。
2	Low Temperature Discharge Characteristics 低温放电性能	Charge the battery with standard charging mode, put the battery into the constant temperature box with $-20 \pm 2^\circ\text{C}$ for 24h then discharge with 1C to 1.8V. The discharge capacity is required $\geq 60\%$ nominal capacity. 将电池按标准充电模式充好电后，放入 $-20 \pm 2^\circ\text{C}$ 恒温箱中静置 24h 后以 1C 电流放电至 1.8V，要求放电容量 $\geq 60\%$ 标称容量。
3	Over-charge Protection Characteristics 过充电保护性能	Under the temperature of $25 \pm 2^\circ\text{C}$, discharge the battery to 2.0V with 1C current, then charge the battery with 1C current to 5V or for 90min(stop charge while either of the terms reaches firstly). It is required the battery should be no leakage, no fire and no explosion during the test process. 在 $25 \pm 2^\circ\text{C}$ 温度条件下，将电池按 1C 放电到 2.0V，然后以 1C 电流充电到 5V 或以 1C 电流充电 90min（其中一个优先达到，即停止充电）要求测试过程中电池应不漏液、不起火、不爆炸。
4	Over-discharge Protection Characteristics 过放电保护性能	Under the temperature of $25 \pm 2^\circ\text{C}$, after discharging the battery with 1C to 2.0V, then continue discharge the battery to 0V with 1C current. It is required the battery should be no leakage, no fire and no explosion during the test process. 在 $25 \pm 2^\circ\text{C}$ 温度条件下，将电池按 1C 放电至 2.0V 后，继续用 1C 电流将电池放电到 0V，要求测试过程中电池不漏液、不起火、不爆炸。
5	Short-circuit Protection Characteristics 短路保护性能	Under the temperature of $25 \pm 2^\circ\text{C}$, charge the battery with standard charging mode, then short-circuit the anode and cathode for 10min(the connecting resistance is less than $10\text{m}\Omega$), then disconnect the anode and cathode. There should be no leakage, no smoking and no explosion during the test process. 在 $25 \pm 2^\circ\text{C}$ 温度条件下，将电池按标准充电模式充好电，将电池正负极短路（外接电阻小于 $10\text{m}\Omega$ ）持续 10min，再将电池正负极断开，测试过程中电池应不漏液、不冒烟、不爆炸。
6	Drop Test 跌落实验	Under the temperature of $25 \pm 2^\circ\text{C}$, charge the battery with standard charging mode, then drop it freely from 1 meter height onto the hard wood board which is 18-20mm thick(5 directions, each of X+, X-, Y+, Y-, Z- except anode and cathode direction Z+). The battery should be no smoking and no explosion. The battery discharging performance with 0.5C current need to be tested after the drop test is completed. The discharge capacity is required $\geq 30\text{Ah}$ (The battery should be cycled no more than 3 times, if any time passed among them, then stop.). 在 $25 \pm 2^\circ\text{C}$ 温度条件下，0.5C 充满电后，将电池从 1 米高度自由跌落至厚度为 18~20mm 硬木板上（除极柱方向 Z+ 外，X+, X-, Y+, Y-, Z- 电池的五个方向分别朝下跌落一次）电池不冒烟、不爆炸。试验结束后，进行 0.5C 放电性能测试，要求放电容量 $\geq 30\text{Ah}$ （最多可 3 次循环，任何一次合格即可停止）。



3.7 Rest Period 搁置时间

Unless otherwise defined, rest 10min after charge, rest 10min after discharge.

如无特殊要求，电池充放电间隔为 10min。

4. Storage and Others 贮存及其它事项

4.1 Long Time Storage 长期贮存

If stored for a long time (Over 3 months), the battery should be stored in dry and cool place, the state of charge should be 50%. And the battery should be stored in a condition as appendix No.4

长期贮存的电池 (>3 个月) 须置于干燥、凉爽处，且带电量要求 50%SOC。贮存环境要求如附录 4。

4.2 Others 其它事项

Any matters that this specification does not cover should be conferred between the customer and manufacturer.

任何本说明书中未提及的事项，须经双方协商确定。

5. Battery Size Draft 电池外形尺寸图

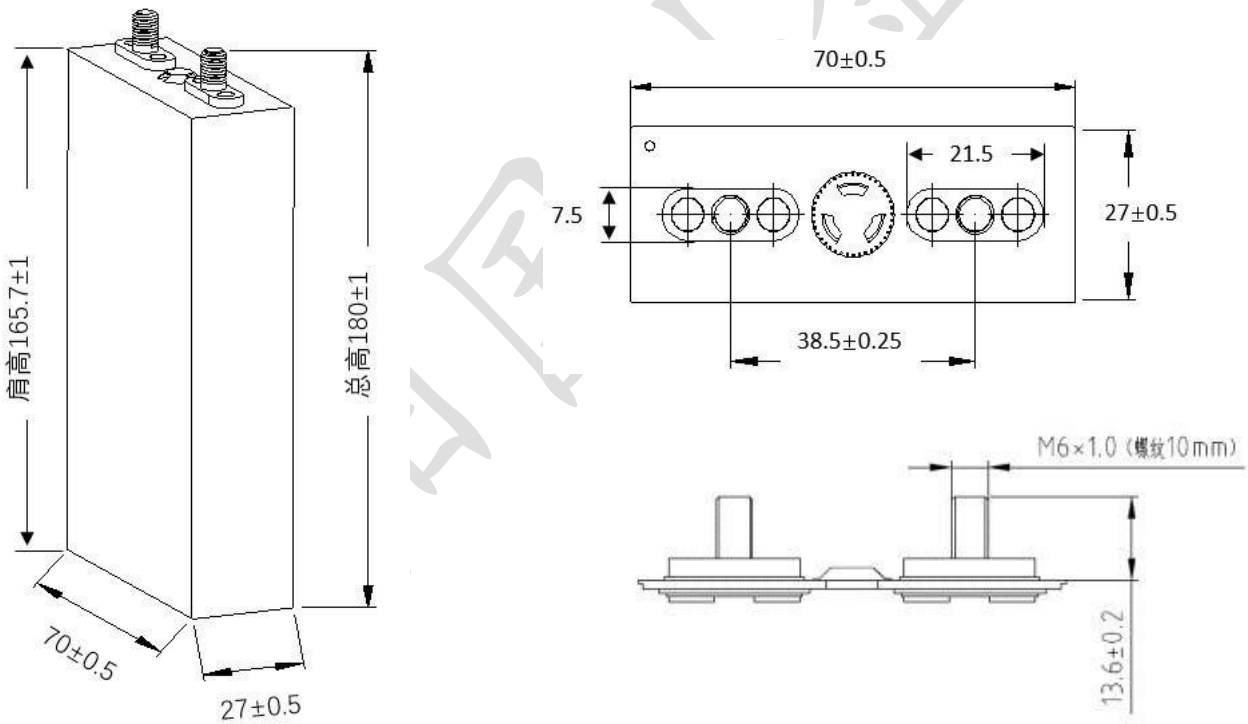

Appendix 附录

Handling Precautions and Guideline

For Rechargeable Batteries

锂离子充电电池操作指示及注意事项

Preface 前言

本档“锂离子充电电池操作指示及注意事项”仅适用于沈阳国科金能科技有限公司生产的电池。

Note(1): 声明一

客户若需要将电池用于超出本规格书规定以外的设备，或在本规格书规定以外的使用条件下使用电池，应事先联系沈阳国科金能科技有限公司，因为需要进行特定的实验测试以核实电池在该使用条件下的性能及安全性。

Note(2): 声明二

对于在超出本规格书规定以外的条件下使用电池而造成的任何意外事故，沈阳国科金能科技有限公司概不负责。

Note(3): 声明三

如有必要，沈阳国科金能科技有限公司会以书面形式告知客户有关正确使用使用电池的改进措施。

1. Charging 充电

1.1 Charging current 充电电流

Charge the cell at a constant current of 0.5C until 3.65V, and then at a constant voltage of 3.65V until 0.05C. Charge rates greater than 1C are not recommended. (C : Rated Capacity of cell)
以 0.5C 的电流恒流充电至 3.65V，然后以 3.65V 的电压恒压充电至电流为 0.05C，超过 1C 的电流建议不要使用

1.2 Charging voltage 充电电压

The charging voltage exceeding the rated voltage(3.65V) specified was forbidden in this specification on document. The maximum of charging voltage is 3.7V. The setting of protection voltage should be complied with this condition for the PACK protection system.

充电电压不得超过本规格书规定的额定电压（3.65V）。3.7V 为充电电压最高极限，PACK 保护系统的保护电压设置应满足此条件。

It is very dangerous that charging with higher voltage than the maximum voltage may cause damage to the battery's electrical, mechanical and safe performance and could lead to heat generation or leakage.

电池电压高于额定电压值时，将可能引起电池的充放电性能、机械性能和安全性能的问题，可能会导致发热或漏液。电池电压高于额定电压值时，将可能引起电池的充放电性能、机械性能和安全性能的问题，可能会导致发热或漏液。

1.3 Charging temperature 充电温度

Charge the cell in the best temperature range of 25°C±2. 电芯最佳充电温度范围为 25°C±2。

1.4 Prohibition of reverse charging 禁止反向充电

Reverse charging is strictly prohibited. The battery shall be connected correctly. The polarity has to be confirmed before wiring. In case of the battery is connected improperly, the cell cannot be charged. Simultaneously, the reverse charging may cause damaging to the cell which may lead to degradation of cell performance and damage the cell safety, and could cause heat generation or leakage.

严禁反向充电。应正确连接电池的正负极。接线前应将电池正负极固定。若电池正负极接反，将无法对电池进行充电。同时，反向充电会降低电池的充放电性能、安全性，并会导致发热、漏液。

2. Discharging 放电

2.1 Discharging current 放电电流

2.2 Recommended cut-off voltage to 2.0V. Recommended max continuous discharge current is 3C. 建议放电终止电压为 2.0V，建议最大持续恒流放电电流为 3C。

2.3 Discharging temperature 放电温度

For maximum performance, we suggest the discharge temperature at $25^{\circ}\text{C} \pm 2$. 为了达到较好的性能，电芯的放电温度范围为 $25^{\circ}\text{C} \pm 2$ 。

2.4 Over-discharging 过放电

It should be noted that the battery would be at an over-discharged state by its self-discharge characteristics in case the batteries not used for long time. In order to prevent over-discharging, the battery shall be charged periodically to maintain regular charging (charge and discharge at least once every 3 months).

需要注意的是，在电池长期未使用期间，可能因为其自放电特性而使电池处于过放电状态。为防止过放电的发生，电池应定期充电(每 3 个月至少充放电一次)。

Over-discharging may cause loss of cell performance or battery functions
过放电会导致电池性能、电池功能的丧失。

3. Storage 贮存

The optimal storage temperature for batteries is $25^{\circ}\text{C} \pm 2^{\circ}\text{C}$, and the state of charge (SOC) should be 50%..
电池最佳储存温度 $25^{\circ}\text{C} \pm 2^{\circ}\text{C}$ ，带电状态 50%SOC。

If the battery has to be storied for a long time (Over 3 months), the environmental condition should be :
temperature: $25^{\circ}\text{C} \pm 2^{\circ}\text{C}$, humidity: $65 \pm 20\% \text{RH}$. Charge and discharge at least once every 3 months.

若要长期存储电池（超过 3 个月）须置于温度为 $25^{\circ}\text{C} \pm 2^{\circ}\text{C}$ 、湿度为 $65 \pm 20\% \text{RH}$ 的环境中，超过 3 个月，需至少重新充放电 1 次。

4. Handling Instructions 电池的注意事项

认真阅读下面的注意事项，确保正确使用锂离子电池。沈阳国科金能科技有限公司对违反下述注意事项而产生的任何问题不予负责。

Danger!

危险!

- Do not immerse the battery in water or allow it to get wet.
- 勿将电池投入水中或将其弄湿!
- Do not use or store the battery near heat sources such as fire or heater.
- 勿在热源（如火或加热器）附近使用或贮存电池!
- Do not charge the battery near a fire or heat sources.
- 禁止在火源或极热条件下给电池充电!
- Do not use any chargers other than those recommended.
- 请使用专用充电器!
- Do not reverse the positive(+) and negative(-) terminals.
- 勿将正负极接反!
- Do not connect the battery directly to wall outlets or car cigarette-lighter sockets.
- 勿将电池直接连接到墙上插座或车载点烟式插座上!
- Do not put the battery into a fire or apply direct heat to it.
- 勿将电池投入火中或给电池加热!
- Do not short-circuit the battery by connecting wires or other metal objects to the positive(+) and negative(-) terminals.
- 禁止用导线或其它金属物体将电池正负极短路。禁止将电池与项链、发夹或其它金属物体一起运输或贮存!
- Do not pierce the battery casing with a nail or other sharp object, break it open with a hammer, or step on it.
- 禁止用钉子或其它尖锐物体刺穿电池壳体，禁止锤击或脚踏电池!
- Do not strike, throw or subject the battery to sever physical shock.
- 禁止撞击、投掷或者使电池受到机械震动!
- Do not directly weld the battery terminals.
- 禁止直接焊接电池端子!
- Do not attempt to disassemble or modify the battery in any way.
- 禁止以任何方式分解电池!

- Do not place the battery in a microwave oven or pressurized container.
- 禁止将电池置入微波炉或压力容器中！
- Do not use the battery in combination with primary batteries (such as dry-cell batteries) or batteries of different capacity, type or brand.
- 禁止与一次电池（如干电池）或不同容量、型号、品种电池组合使用！
- Do not use the battery if it gives off an odor, generates heat, becomes discolored or deformed, or appears abnormal phenomenon in any way. If the battery is in use or being charged, remove it from the device or charger immediately and discontinue use.
- 如果电池发出异味、发热、变形、变色或出现其它任何异常现象时不得使用；如果电池正在使用或充电，应立即从用电器中或充电器中取出并停止使用！

Caution!

注意！

Do not use or store the battery where is exposed to extremely hot, such as under window of a car, in direct sunlight in a hot day. Otherwise, the battery may be overheated. This can also reduce battery performance and/or shorten calendar life.

不要在极热环境中使用电池，如阳光直射或热天的车内。否则，电池会过热，可能着火（点燃），这样就会降低电池的性能，缩短电池的使用寿命。

If the battery leaks and electrolyte gets in your eyes, do not rub them. Instead, rinse them with clean running water and immediately seek medical attention. If left as is, electrolyte can cause eye injury.

如果电池漏液后电解液进入眼睛，不要擦，应用水冲洗，立即寻求医疗救助。如不及时处理，眼睛将会受到伤害。

Use the battery only under the following environmental conditions. Failure to do so can result in reduced performance or a shorten calendar life. Recharging the battery outside of these temperatures can cause the battery to overheat, explode or catch fire.

只能在下述条件下使用电池，否则将会降低电池的性能或缩短电池的使用寿命。在下述温度范围之外充电将会导致电池过热、爆炸或起火。



Web site: www.gkpower.cn

Address: No. 603 Wheat village, Hunnan District, Shenyang City, Liaoning Province

TEL: 024-31920506

网址: www.gkpower.cn

地址: 辽宁省沈阳市浑南区麦子屯 603 号

电话: 024-31920506